



SBC28.2 &
VBZ 1/2...1 1/4

2-position electric actuators with Ball valves **SBC28.2** **VBZ 1/2...1 1/4**

90° angle - Unidirectional rotation

Electric rotary actuators for two-port ball valves

- SBC28.2 Operating voltage AC 230 V
- 2-position control signal
- Nominal angle of rotation 90°
- For mounting on two-port ball valves
- With position indicator

Application

For use in heating, ventilation and air conditioning systems to operate two-port ball valves, types VBZ 1/2" – 3/4" – 1" – 1 1/4"

Functions

If the actuator is driven by a 2-position signal from the controller, it generates a rotary motion, which is transferred to the valve.

Extending the actuator functions

Refer to the wiring diagram on the actuator cover and see also the "Commissioning" and "Connection diagram" sections in this data sheet.

Types

Type	Operating voltage	Type of control	Run-time for 90° at 50 Hz	Optional
SBC28.2	AC 230 V	2-position	90"	-

Mounting kits No mounting kits is required

Ordering

When ordering, please specify the quantity, product name and type code.

Example: 1 actuator, type SBC28.2 and 1 valve type VBZ1"

Delivery The actuator and ball valve are packed together and are not delivered fully assembled.

Compatibility

The table below shows which actuators may be used with which ball valves,

Valves	Nom. pressure [bar]	Actuator
		SBC28.2
		Nominal size
Two-port ball valves		
VBZ... (1/2" ... 1 1/4")	PN16	1/2" - 3/4" - 1" - 1 1/4"

Mechanical design

The electric actuators require no maintenance. They have a synchronous unidirectional motor and **self-lubricating sintered gears** contained in a plastic box.

The actuators supplied have a 90° angle of rotation suitable for the ball valves. During automatic operation, rotation is limited by two built-in end-switches.

Engineering

- Two-port ball valves see: data sheets 4831.2.
- Admissible ambient temperatures see "Technical data".

Electrical installation

The actuators must be electrically connected in accordance with local regulations and with the connection diagrams.



Regulations and requirements to ensure the safety of people and property must be observed at all times.

Mounting

Mounting instructions are printed on the box.

The valve and actuator can be assembled easily on site. There is no need for special tools or calibration.

Take care to install the valve the right way up. Refer to the mounting instructions for the valve concerned.

Orientation

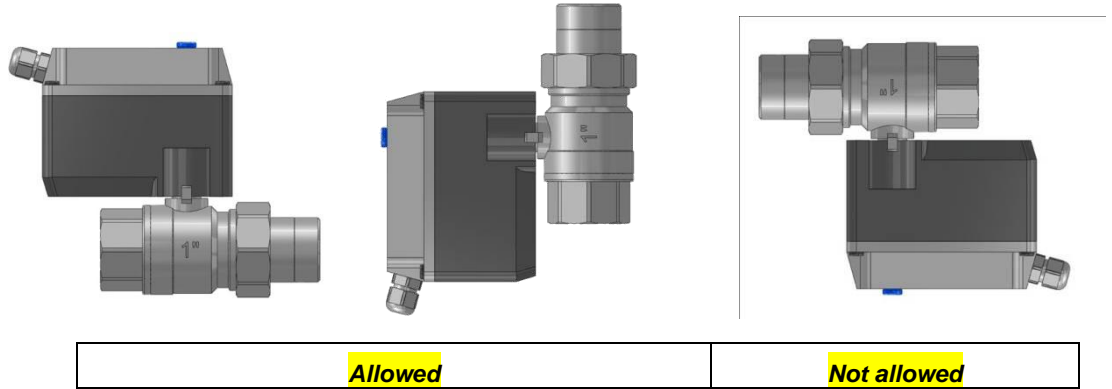

Commissioning

When commissioning the complete motorised valve, consisting of actuator and ball valve, check the wiring and test the functions. This also applies to any additional components fitted.

Direction of rotation

Position indication

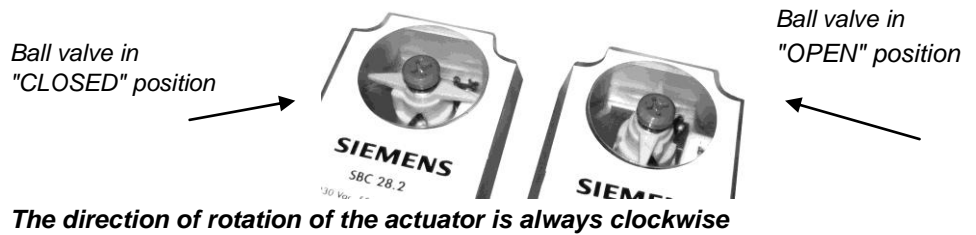

Voltage at brown = ball valve CLOSED
 Black connected at brown = ball valve OPEN

Maintenance

Warning

When servicing the valve and/or actuator: switch OFF the pump and power supply, close the main shut-off valve in the pipework, release pressure in the pipes and allow them to cool down completely.

If necessary, disconnect electrical connections from terminals.

Warranty

The technical data given for these applications is valid only in conjunction with the Siemens valves (ball valves). The use of third-party valves other than those recommended by Siemens invalidates the warranty.

Technical data

Power supply	Operating voltage SBC28.2	AC 230 V	
	Frequency	50 / 60 Hz	
	Type of control	2-position	
	Absorbing power SBC28.2	At start 4 VA	In operation 3.6 VA
Operating data	Run-time for rotation through 90° SBC28.2	<u>at 50 Hz</u> 90"	<u>at 60 Hz</u> 85"
	Angle of rotation Factory setting	90° ± 2°	
	Torque: SBC28.2	<u>Max Working torque</u> 5 Nm	<u>Max torque</u> 14 Nm
	End switch Switching capacity Switching differential	AC 250 V, 6 (2) A Approx. 1°	
Materials	Reduction unit	Plastic / Sintered / Case-hardened steel	
	Box	Plastic (Noril® - PC)	
Dimensions / Weight	Dimensions	See "Dimensions"	
	Cable glands	M12 (4x)	
	Weight SBC28.2	600 gr.	
Ambient conditions	Max. admissible temperature of medium in assembled valve	110 °C	
	Operation	To IEC 60721-3-3	
	– Environmental conditions	Class 3K5	
	– Temperature	-5 ... +55 °C	
	– Humidity	5 ... 95 % rh	
Transport	To IEC 60721-3-2		
– Environmental conditions	Class 1K3		
– Temperature	-20 ... +70 °C		
– Humidity	< 95 % rh		
Storage	To IEC 60721-3-1		
– Environmental conditions	Class 1K3		
– Temperature	-20 ... +70 °C		
– Humidity	0 ... 95 % rh		
Industry standards	Meets the requirements for CE marking in EMC Directive	EN55014	
	Low Voltage Directive	EN60335/EN62233	
	Housing protection standard	IP54 to IEC529 / DIN40050	

Connection diagrams

SBC28.2

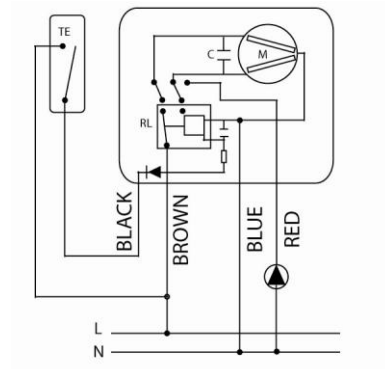

- L Operating voltage
- N Neutral conductor
- TE 2-position controller (thermostat)

The actuator don't need the ground wire because it is an Isolation Class II

Protection against the electric shock is guaranteed by the connection of metallic parts to the protection grounding circuit.

Dimensions

SBC 28.2

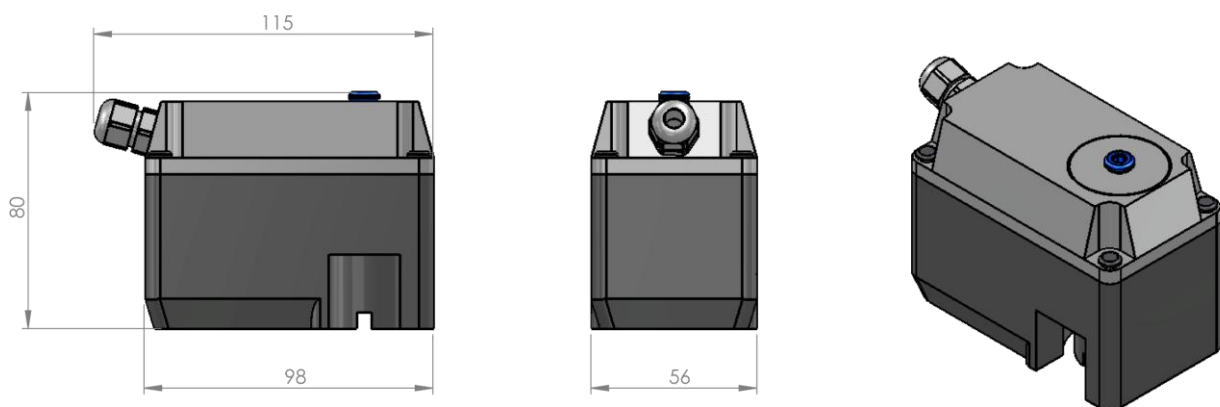

VBZ1/2-3/4-1-11/4 specifications

Specification

Installation: assembling in rigid pipework, for industrial, pneumatic and hydraulics installations, ecc.

Temperature range: 0°C /+ 95°C (110° max. 30 min)

Direction of flow: as desired

Working pressure: PN 40 to 95°C / PN 16 to 110°C

Max. differential pressure: 8 bar

Torque: 1 to 3 Nm

Thread ends: Gas UNI ISO 228

VBZ1/2-3/4-1-11/4 dimensions

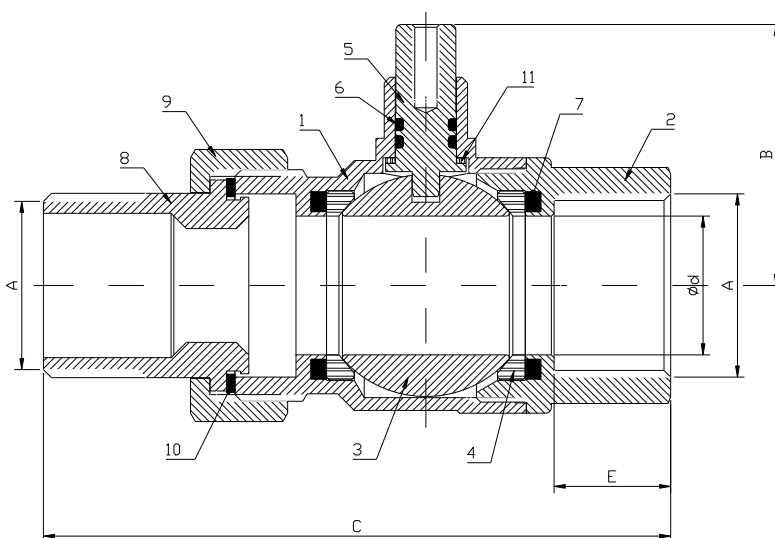

POSITION	DESCRIPTION	TREATMENT	MATERIAL	NORME	QUANTITY
1	Body hot pressed brass	Chrome plated	CW617N	UNI EN 12165	1
2	Nipple hot pressed brass	Chrome plated	CW617N	UNI EN 12165	1
3	Ball	Chrome plated	CW617N	UNI EN 12165	1
4	P.T.F.E. Ring	/	P.T.F.E.	BS6564	2
5	Stem	Chrome plated	CW614N	UNI EN 12164	1
6	Oring	/	Viton 70	ASTM D 2000	2
7	Oring	/	NBR 70	ASTM D 2000	2
8	Union	Chrome plated	CW617N	UNI EN 12165	1
9	Nut	Chrome plated	CW617N	UNI EN 12165	1
10	Oring	/	NBR 70	ASTM D 2000	1
11	P.T.F.E. Ring	/	P.T.F.E.	BS6564	1

A	1/2"	3/4"	1"	1 1/4"
D	15	20	25	32
B	39.5	43	47	52
C	83.5	96	113	125.5
E	17	19	21	22
Kvs (m ³ /h)	16,5	23	41,5	85
Weight (gr.)	245	400	680	895

Assembling the actuator with the ball valve

SBC28.2 &
VBZ1/2...11/4

1.

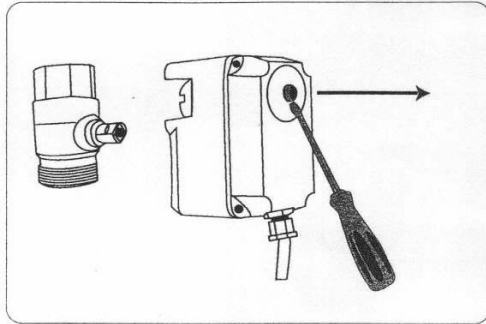

2.

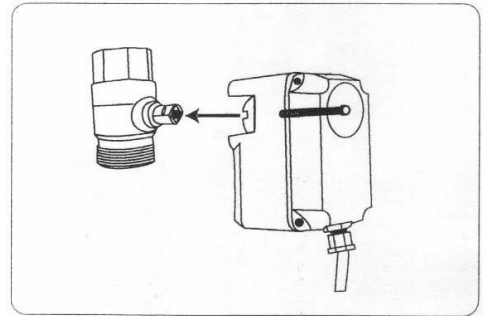

3.

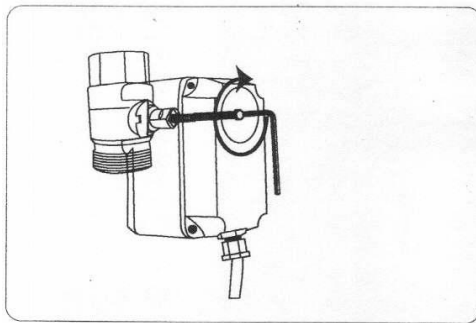

4.

