



Made in Italy



## VARIABLE FREQUENCY DRIVE FOR CONTROL AND PROTECTION OF THE PUMP

Varies the number of motor revolutions of the pump depending on the water withdrawn by the system in order to maintain constant flow and pressure.

Can be installed on surface and submerged pumps.

Allows to regulate the system pressure and the cut-in pump pressure.

Stops the pump in case of water shortage and protects it from dry running.

Ensures energy savings.

No need for an expansion tank, check valve, filter or fittings.

---

Certified by TÜV SÜD

---

## CONTROL AND ADJUSTMENT PANEL

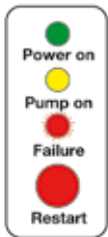
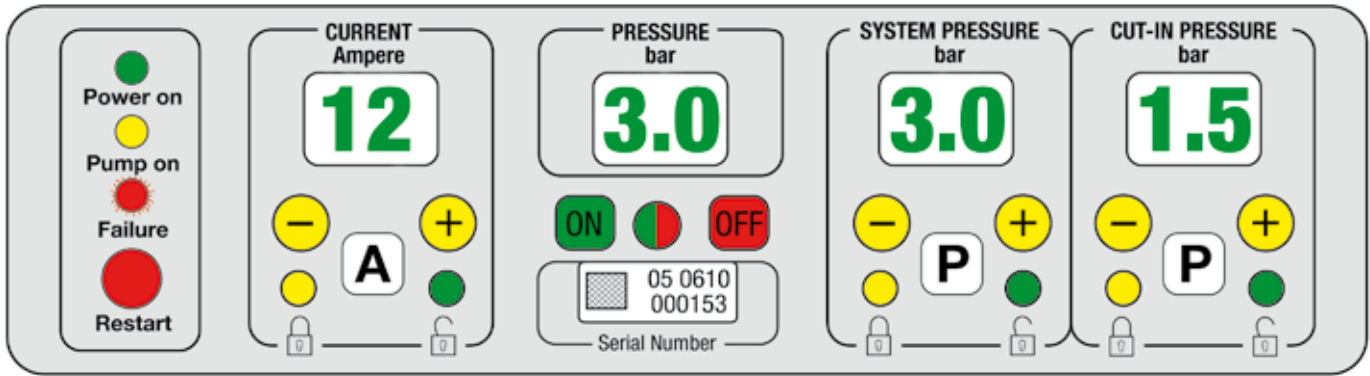

Power On	Green LED on	Device energised
Pump On	Yellow LED on	Pump running
Failure	Red LED blinking	Water shortage or malfunctioning
Restart	Button	Reset after failure
<b>A</b> <b>P</b>	Buttons	Access and locking of keypad



### SETTING THE VALUE OF THE CURRENT ABSORBED BY THE MOTOR

Read the value of the current in Amperes on the pump motor nameplate. Press the **A** button (green LED lit up) and set the value on the display using the **+** (plus) and **-** (minus) buttons (0.5 A steps). Set the value by pressing the **A** button (yellow LED lit up) to lock the adjustment just made. When the pump is running the real motor absorption value will appear on the display.

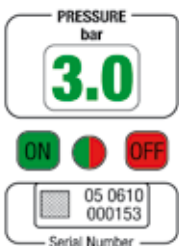

Manometer	Indicates the real value of the system pressure.
Switch	{ Press the green <b>ON</b> button (green LED lit up) to start the pump and the <b>OFF</b> button to turn it off (red LED lit up).
Identification	Specific serial number and data of the device.

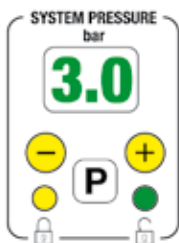

### SETTING THE VALUE OF THE SYSTEM PRESSURE

Press the **P** button (green LED lit up) and set the value on the display using the **+** (plus) and **-** (minus) buttons (0.5 A steps). After setting the desired value, press the **P** button (yellow LED lit up) to lock the adjustment made.

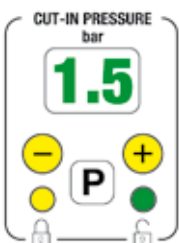

### SETTING THE CUT-IN VALUE OF THE PUMP

Press the **P** button (green LED lit up) and set the value on the display using the **+** (plus) and **-** (minus) buttons (0.1 bar steps). After setting the desired value, press the **P** button again (yellow LED on) to lock the adjustment made.

## INSTALLATION AND START UP

Mount the device in a vertical position directly on the pump or between the pump and the first user.

**Make all electrical connections following the diagrams indicated below and connect to main power supply.**

On the control panel the green "Power on" LED and the red **OFF** LED on the switch will light up.

Blinking dashes will appear on all the displays while the device carries out the set-up operations. When the set-up is completed the factory-set current and pressure values will appear on the display (CURRENT 1.5 A - SYSTEM PRESSURE 3.0 bar - CUT-IN PRESSURE 1.5 bar), the "Current" display will start blinking and the yellow **A** and **P** LEDs will light up.

The value of the pressure in the system will appear on the Pressure display.

**Set the current value absorbed by the motor as indicated on the relative nameplate.**

To adapt the plant to the desired operations, different pressure values can be set than the factory-set ones: system pressure 3 bar - cut-in pressure 1.5 bar.

The set pressure value of the system must be lower than the maximum effective pressure generated by the pump and compatible with the desired pump delivery.

The set cut-in pressure value must be higher than the pressure extended on the device by the water column height.

**After setting the values, press the **ON** button on the switch (green LED lit up) to start.**

When the pump is in operation the real value of the current absorbed by the motor will appear on the Current display.

## EXAMPLE OF PARAMETERS SETTING

### - CURRENT

Adjustment step 0.5A up to 10 A -1A over 10A

Set the value immediately over the value of A indicated on the nameplate.

Example: motor current (on nameplate) 6.3 A → max 6.5 A

### - SYSTEM PRESSURE

Adjustment step 0.5 bar.

Set the desired value **lower than the maximum effective pressure** generated by the pump.

Example: maximum pump pressure 9 bar → max 8,5 bar

### - CUT-IN PRESSURE

Adjustment step 0.1 bar

Set the desired value higher of at least **~0.5 bar than the pressure** exerted by the water column.

Example: water column pressure 1 bar → min 1.5 bar

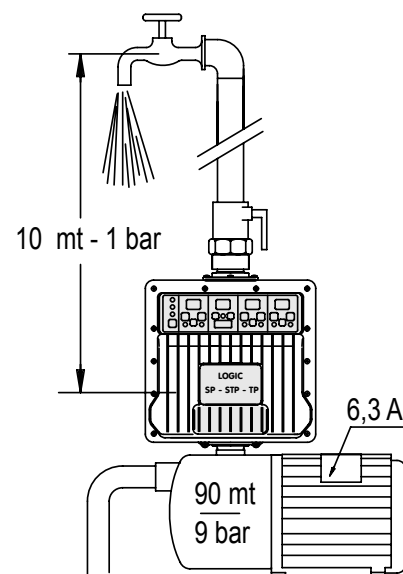

It is possible to change the set pressure values even while the pump is operating.

Before changing the value of the absorbed current (amperes) of the motor, press the **OFF** button (red LED lit up) of the switch on the current display.

## AUTOMATIC RESTART AND ANTI-JAMMING FUNCTION

In case of stopping due to a water shortage, the device will automatically make 10 double attempts to rearm over the 24 hours following the failure, each lasting approximately 5 seconds to allow the pump and the system to reload if possible. After the last failed rearming attempt, the device will remain permanently in alarm (red Failure LED blinking) pending manual rearming by pressing the Restart button .

The user can try to rearm the device at any time by pressing the Restart button .

If for any reason the pump remains idle for 24 consecutive hours, the device will carry out a start up of the pump motor for about 5 seconds.

In case of a temporary blackout, the device will automatically rearm once the electricity returns.

## LOGIC SP - STP - TP SERIES

VOLTAGE/MOTOR MODELS	SP - SINGLE-PHASE/SINGLE-PHASE		
	SP 8,5	SP 11	SP 13
Mains voltage	1 ~ 230 Vac	1 ~ 230 Vac	1 ~ 230 Vac
Acceptable voltage fluctuations	+/- 15%	+/- 15%	+/- 15%
Frequency (automatic recognition)	50 / 60 Hz	50 / 60 Hz	50 / 60 Hz
Frequency 140 Hz motor	—	—	—
Pump motor voltage	1 ~ 230 Vac	1 ~ 230 Vac	1 ~ 230 Vac
Maximum pump motor current	8,5 A	11 A	13 A
Maximum pump motor power	1,3 kW - 1,7 HP	1,5 kW - 2 HP	2,2 kW - 3 HP
Soft "engine start"	Si	Si	Si
Electrical connection cable to mains H07 RN-F	3G 1,5 mm <sup>2</sup> L 1,5 m schuko plug		
Electrical connection cable to motor H07 RN-F	3G 1,5 mm <sup>2</sup> L 1,5 m		
Length of cable up to 80 m	Yes	Yes	Yes
Maximum operating	16 bar	16 bar	16 bar
Adjustable system pressure	2 ÷ 12 bar	2 ÷ 12 bar	2 ÷ 12 bar
Adjustable cut-in pressure	1 ÷ 11 bar	1 ÷ 11 bar	1 ÷ 11 bar
Minimum flow	~ 1 l/min	~ 1 l/min	~ 1 l/min
Maximum operating temperature	60° C	60° C	60° C
Protection degree	IP 65	IP 65	IP 65
Digital manometer	Yes	Yes	Yes
Digital ammeter	Yes	Yes	Yes
Dry running protection	Yes	Yes	Yes
Timed automatic rearming	Yes	Yes	Yes
Anti-jamming function	Yes	Yes	Yes
Protection fuse	Yes	Yes	Yes
Short-circuit protection between phases	Yes	Yes	Yes
Short-circuit protection between phases and earth	Yes	Yes	Yes
Over-current protection	Yes	Yes	Yes
Voltage surge protection	Yes	Yes	Yes
Over-temperature protection	Yes	Yes	Yes
Pressure sensor fault detection	Yes	Yes	Yes
Removable pressure sensor	Spare part available on request		
Remote ON/OFF connection predisposition	Yes	Yes	Yes
Float switch and level probe connections predisposition	Yes	Yes	Yes
Remote alarm connection predisposition	Yes	Yes	Yes
Accumulation	Incorporated	Incorporated	Incorporated
Check valve	Incorporated	Incorporated	Incorporated
Water discharge	Yes	Yes	Yes
Male connections	1" - 1"	1" 1/4 - 1" 1/4	1" 1/4 - 1" 1/4
Interchangeable male connectors	1" 1/4 - 1" 1/4	1" 1/2 - 1" 1/2	1" 1/2 - 1" 1/2
Stainless steel screws	Yes	Yes	Yes
Overall dimensions and weight	260 x 312 x 285 mm ~ 5 Kg		

Communication between devices —

For each model is available the

## MODELS AND TECHNICAL FEATURES

STP - SINGLE-PHASE/THREE-PHASE		TP - THREE-PHASE/ THREE-PHASE			
STP 8,5	STP 11	TP 6	TP 9	TP 12	TP 16
1 ~ 230 Vac	1 ~ 230 Vac	3 ~ 400 Vac	3 ~ 400 Vac	3 ~ 400 Vac	3 ~ 400 Vac
+/- 15%	+/- 15%	+/- 15%	+/- 15%	+/- 15%	+/- 15%
50 / 60 Hz	50 / 60 Hz	50 / 60 Hz	50 / 60 Hz	50 / 60 Hz	50 / 60 Hz
—	Available on request	Available on request			
3 ~ 230 Vac	3 ~ 230 Vac	3 ~ 400 Vac	3 ~ 400 Vac	3 ~ 400 Vac	3 ~ 400 Vac
8,5 A	11 A	6 A	9 A	12 A	16 A
1,9 kW - 2,5 HP	2,2 kW - 3 HP	2,2 kW - 3 HP	3 kW - 4 HP	5,5 kW - 7,5 HP	7,5 kW - 10 HP
—	—	—	—	—	—
3G 1,5 mm <sup>2</sup> L 1,5 m schuko plug 4G 1,5 mm <sup>2</sup> L 1,5 m		4G 1,5 mm <sup>2</sup>	L 1,5 m	4G 2,5 mm <sup>2</sup>	L 1,5 m
Yes	Yes	Yes	Yes	Yes	Yes
16 bar	16 bar	16 bar	16 bar	16 bar	16 bar
2 ÷ 12 bar	2 ÷ 12 bar	2 ÷ 12 bar	2 ÷ 12 bar	2 ÷ 12 bar	2 ÷ 12 bar
1 ÷ 11 bar	1 ÷ 11 bar	1 ÷ 11 bar	1 ÷ 11 bar	1 ÷ 11 bar	1 ÷ 11 bar
~ 1 l/min	~ 1 l/min	~ 1 l/min	~ 1 l/min	~ 1 l/min	~ 1 l/min
60° C	60° C	60° C	60° C	60° C	60° C
IP 65	IP 65	IP 65	IP 65	IP 65	IP 65
Yes	Yes	Yes	Yes	Yes	Yes
Yes	Yes	Yes	Yes	Yes	Yes
Yes	Yes	Yes	Yes	Yes	Yes
Yes	Yes	Yes	Yes	Yes	Yes
Yes	Yes	Yes	Yes	Yes	Yes
Yes	Yes	Yes	Yes	Yes	Yes
Yes	Yes	Yes	Yes	Yes	Yes
Yes	Yes	Yes	Yes	Yes	Yes
Yes	Yes	Yes	Yes	Yes	Yes
Yes	Yes	Yes	Yes	Yes	Yes
Yes	Yes	Yes	Yes	Yes	Yes
Yes	Yes	Yes	Yes	Yes	Yes
Yes	Yes	Yes	Yes	Yes	Yes
Yes	Yes	Yes	Yes	Yes	Yes
Yes	Yes	Yes	Yes	Yes	Yes
Yes	Yes	Yes	Yes	Yes	Yes
Yes	Yes	Yes	Yes	Yes	Yes
Yes	Yes	Yes	Yes	Yes	Yes
Spare part available on request		Spare part available on request			
Yes	Yes	Yes	Yes	Yes	Yes
Yes	Yes	Yes	Yes	Yes	Yes
Yes	Yes	Yes	Yes	Yes	Yes
Incorporated	Incorporated	Incorporated	Incorporated	Incorporated	Incorporated
Incorporated	Incorporated	Incorporated	Incorporated	Incorporated	Incorporated
Yes	Yes	Yes	Yes	Yes	Yes
1" - 1"	1" 1/4 - 1" 1/4	1" 1/4 - 1" 1/4	1" 1/4 - 1" 1/4	1" 1/4 - 1" 1/4	1" 1/4 - 1" 1/4
1" 1/4 - 1" 1/4	1" 1/2 - 1" 1/2	1" 1/2 - 1" 1/2	1" 1/2 - 1" 1/2	1" 1/2 - 1" 1/2	1" 1/2 - 1" 1/2
Yes	Yes	Yes	Yes	Yes	Yes
260 x 312 x 285 mm ~ 5 Kg		260 x 312 x 320 mm ~ 7 Kg			

**“COM” version that is standardly equipped with interface and communication cable**

---

## PRESSURE SETS - COMMUNICATION BETWEEN DEVICES

---

Each model of Logic Series in the “COM” version is standardly equipped with interface and communication cable

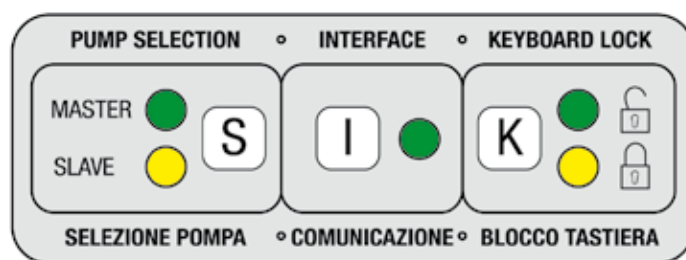

---

## INSTALLATION AND PARAMETERS SETUP

---

Set the current values of all the devices on the Control panel.

Select the Master device and the Slave devices from the communication panel.

To change the set system pressure and cut-in values of both devices, act on the Master device only, even while the pumps are running.

**System pressure values and the cut-in values set on the Master device are automatically transferred onto the Slave devices.**

---

## OPERATION

---

**The Master device controls the Slave devices and manages the operation of the unit.**

Initially, the pump on which the Master device is mounted will start up first, but if the demand for water is such that this pump is unable to maintain the set system pressure values, then the second pump on which the Slave device is mounted will automatically start up.

Every time the pumps stop, it will be the second, third and/or fourth pump etc. to start up first, depending on how many pumps are installed, until finally returning to the Master device and so on.

The alternation of start-up and operation of the pumps that constitute the pressure group, guarantees a uniform wear therefore longer life of the group.

**Act only on the Master device to modify the set pressure values (also while the pumps are running), to connect remote “on/off”, alarm and level probes.**

Master - By pressing the button  (red LED lit up) the Master device is disabled and the unit stops.

Slave - By pressing the button  (red LED lit up) only the relative Slave device is disabled.

---

## ALTERNATING THE PUMPS DURING CONTINUOUS OPERATION

---

If for any reason one or more pumps are working continuously, in order to guarantee uniform wear and tear of the pumps, every sixty minutes of continuous operation of a pump, a forced exchange will be made with another pump on stand-by. The changeover respects the alternating sequence of all the devices.

---

## AUTOMATIC RESTART AND ANTI-JAMMING FUNCTION

---

In case of stopping due to a water shortage, the devices will automatically make 10 double attempts to rearm over the 24 hours following the failure, each lasting approximately 5 seconds to allow the pumps and the system to reload if possible. After the last failed rearming attempt, the devices will remain permanently in alarm (red Failure LED blinking) pending manual rearming by pressing the Restart button .

The user can try to rearm the devices at any time by pressing the Restart button .

If for any reason the pumps remain idle for 24 consecutive hours, the devices will carry out a start up of the pump motor for about 5 seconds without affecting the normal operation of the unit.

In case of a temporary blackout, the pressure set will automatically rearm once the electricity returns.

---

## VARIABLE MASTER

---

In case of malfunctioning of the Master device, the system will transfer the operation to the Slave device immediately upstream from the Master. Once the original Master device has been reset, it will automatically be reintegrated into the system as a Slave device.

PRESSURE SETS EXAMPLES MANAGED BY LOGIC SERIES VARIABLE FREQUENCY DRIVES

