

PRESSURE REDUCING VALVE

EUROBRASS 146

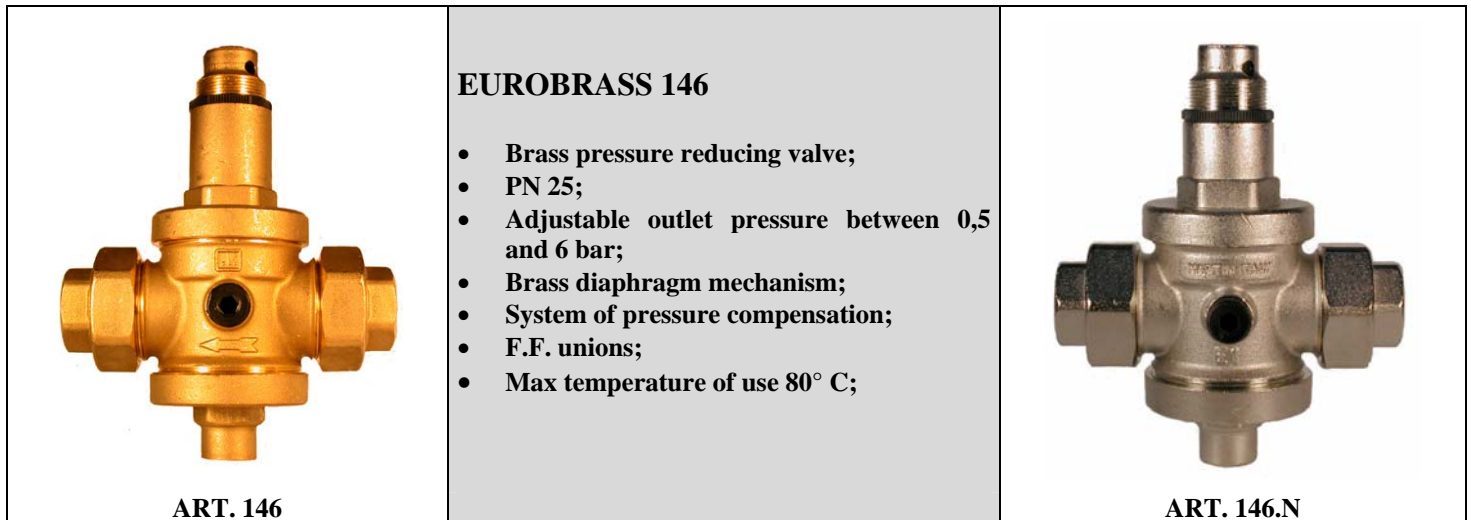

FIELDS:

The pressure reducing valves series EUROBRASS 146 are suitable for reduction and control of pressure in plants with the following characteristics:

Max inlet pressure:	25 bar
Field of action (outlet pressure):	0,5 - 6 bar
Max temperature of use:	80° C
Threading of connection:	ISO 228/1
Product according to rules:	DIN EN 1567
Suitable fluids:	Water, compressed air

MATERIALS:

Metal of the body:	Brass alloy CW617N UNI EN 12165 - CB753S EN 1984
Metal of the inner parts:	Brass alloy CW614N UNI EN 12164
Seat:	Stainless steel AISI 303
Bar:	Brass alloy CW614N UNI EN 12164 Stainless steel AISI 303¹
O-rings:	NBR 70sh
Flat gaskets:	Fasit Italy
Plastic parts:	Ultramid® A3K (BASF)

¹ Sizes from 1"¼ to 2"

MAIN DIMENSIONS OF THE PRESSURE REDUCING VALVES EUROBRASS 146

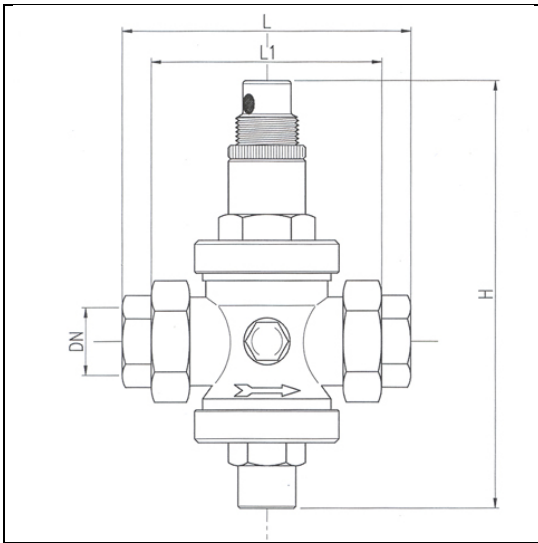

ITEM	DN	H	L	L1
146.12	1/2"	120	112	75
146.34	3/4"	160	135	88
146.33	1"	166	140	93
146.114	1" 1/4	220	170	110
146.112	1" 1/2	220	175	110
146.58	2"	250	200	130

DISCHARGE AND HEADLOSS CHART:

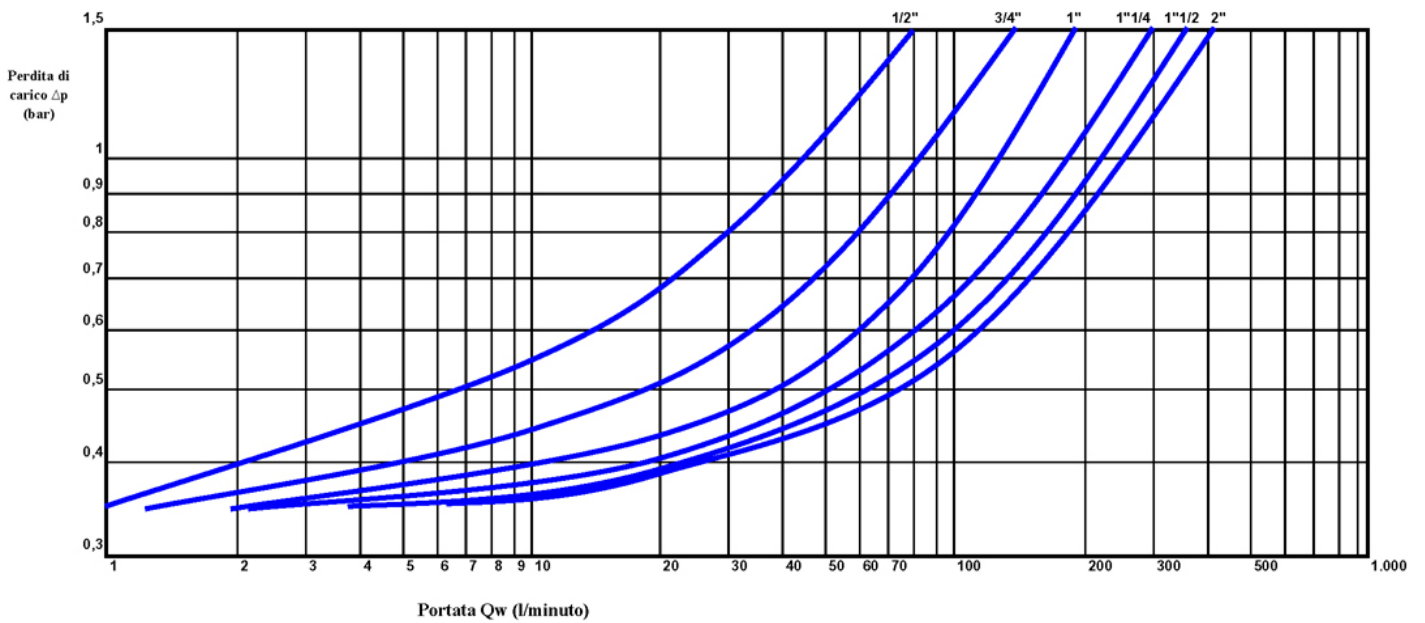

BEST HYDRAULIC DISCHARGE OF PRESSURE REDUCERS EUROBRASS 146²

In order to choose the best pressure reducers for any plant, we suggest to follow the indications mentioned in the underexposed table with the best running pressure of the valves Eurobrass 146; the values are exposed both in litres/minute and cbm/hour, and indicate the field of use where you can obtain the best functioning, silence and smaller loss of charge of the valves.

MODEL	SIZE	AVERAGE HYDRAULIC DISCHARGE	
		L/min	Cbm/hour
EUROBRASS 146	½"	20 - 50	1,2 - 3
EUROBRASS 146	¾"	50 - 75	3 - 4,5
EUROBRASS 146	1"	75 - 95	4,5 - 6
EUROBRASS 146	1" ¼	95 - 130	6 - 8
EUROBRASS 146	1" ½	110 - 140	7 - 8,5
EUROBRASS 146	2"	120 - 160	7,5 - 10

INSTALLATION OF THE PRESSURE REDUCING VALVE

The pressure reducers EUROBRASS 146 don't get the effects – for their functioning – of the gravity force; therefore they can be installed in the plant in any position:

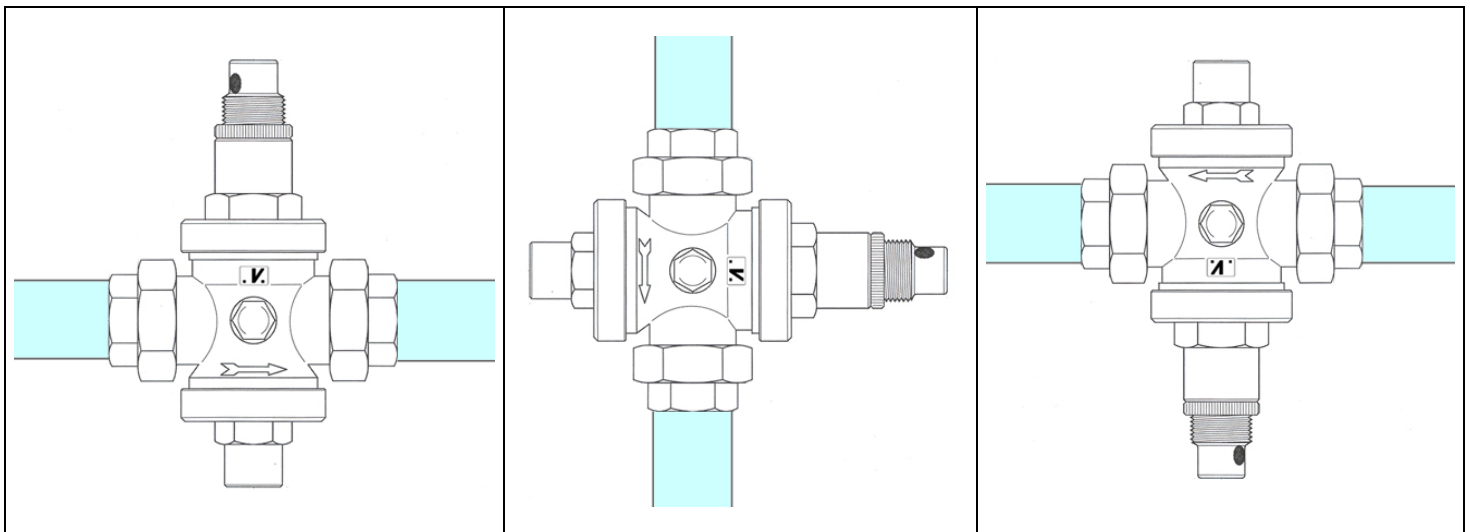

Pressure reducing valves can be damaged by dirty water; therefore we advise to install a self-cleaning filter upstream before the pressure reducer, in order to protect the valve and any other mechanism.

When there is a boiler, sometimes an anomaly of functioning may occur, due to the raise in pressure that follows the temperature rising; an expansion vessel between the boiler and the pressure reducing valve will avoid this problem.

We recommend moreover to install a check valve or an expansion vessel to prevent a pressure bang which would damage the inner parts of the pressure reducer.

² Test by ISTITUTO GIORDANO SPA - Bellaria - Italy

A correct installation of the pressure reducing valve:

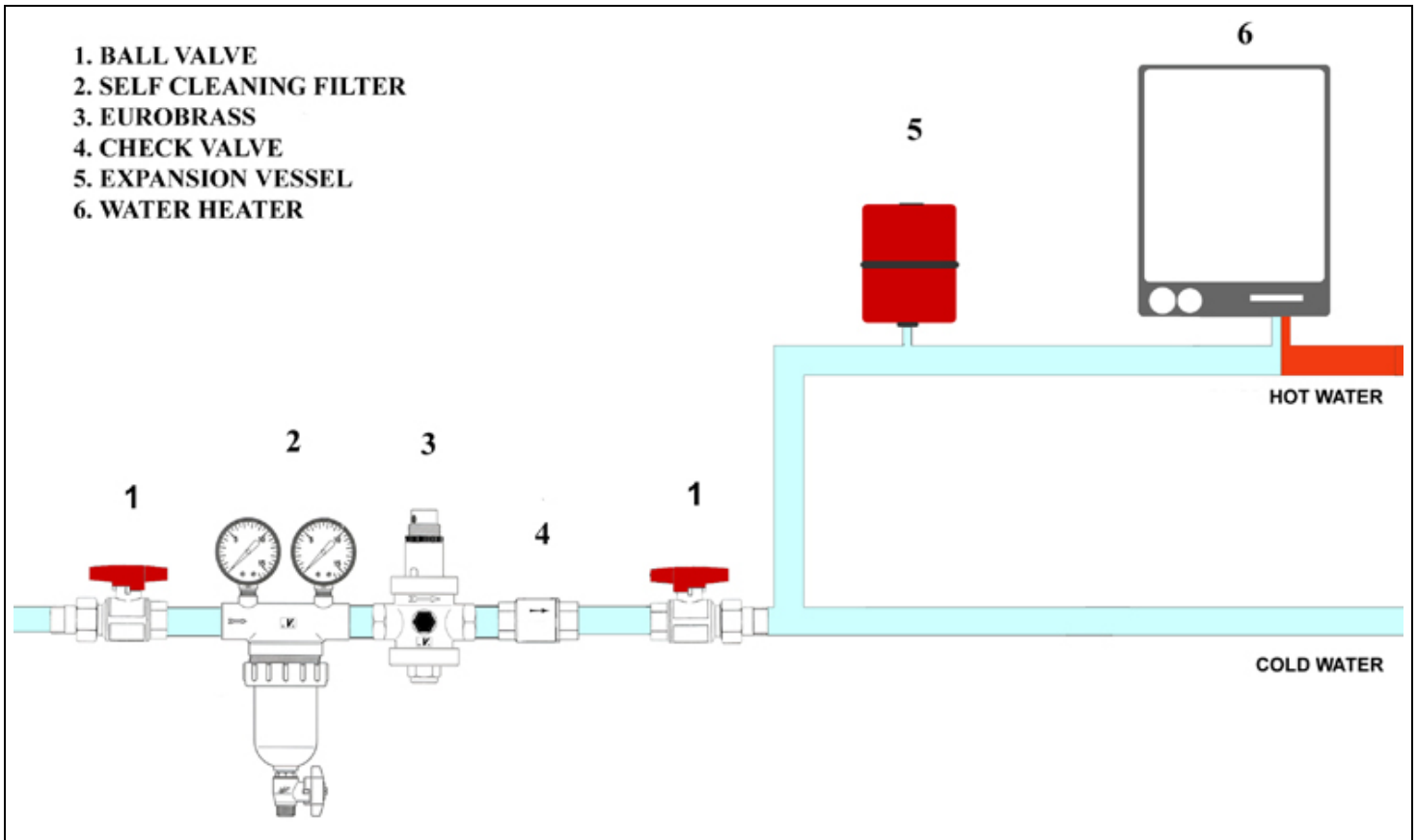

HOW TO REGULATE THE PRESSURE

All Malgorani pressure reducers are tested before being packaged; during the proof they are pre-set at the outlet pressure of 3 bars; the outlet pressure can be easily modified when the valve is installed on the plant.

In order to modify the outlet pressure, you should only loosen the fixing ring and turn the spring holder as indicated in the pictures sequence. By turning clockwise the pressure increases, while counter-clockwise the pressure decreases.

A right setting should be made while the plant is closed.

